

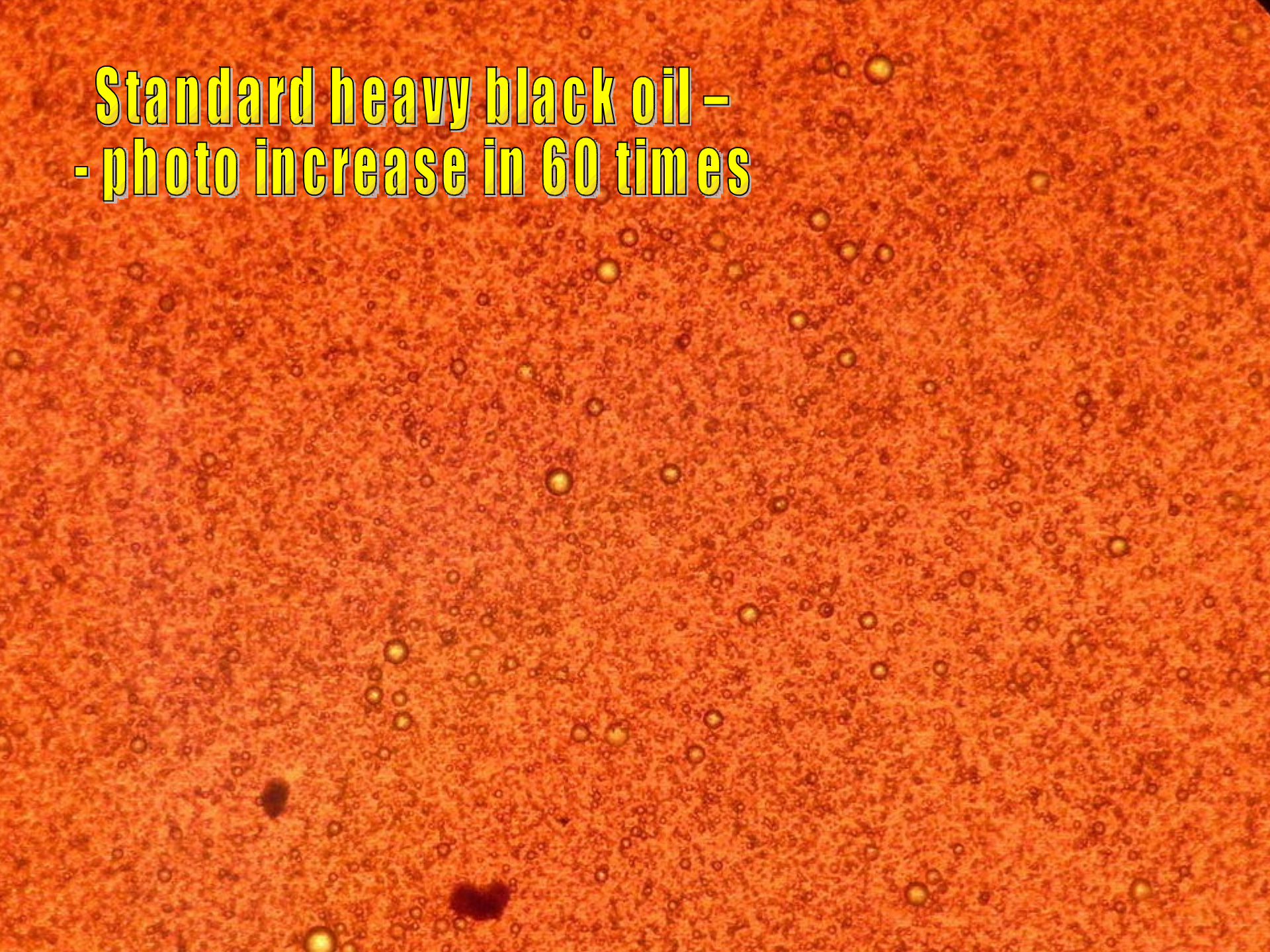

TRGA - devices for full burning and economy boiler fuel (standard and heavy black oil)

TRGA – device without any addition or chemical catalysts.
Fair history of one real installation.
www.afuelsystems.com.ua

**Standard heavy black oil –
- photo increase in 60 times**



**Heavy black oil after processing on TRGA -
- photo increase in 60 times**

Technical results

On the basis of the analysis, more than 800 patents of the Russian Federation and 350 patents of Ukraine, We created a ruler units, with high efficiency and productivity (3-120 m. c. p/h), with minimal power consumption (1 kW/h on 1 m. c. p/h and less), with minimal weight and dimensions.

That has allowed to create compact modules for fuel processing or install one into boiler fuel feed with work from regular force pumps.



TRGA- 20 m. cub. P/h

Technical results



**Module for
fuel
processing
boiler fuel
– work
from
august
2009.**

**Private
enterprise
Ukraine.**

Technical results



Install in boiler fuel feed with work from regular force pumps.

Base for storage nuclear warheads Ukraine.

Work from dec. 2009

Эмульгатор

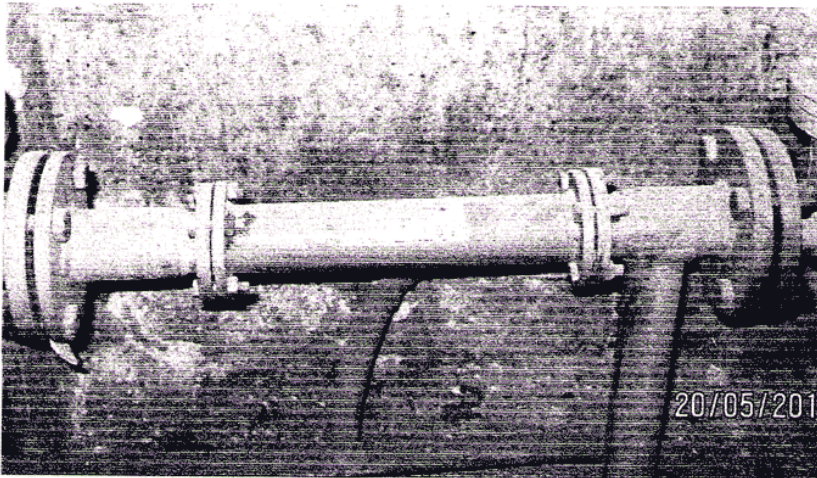

Эмульгатор и теплообменники

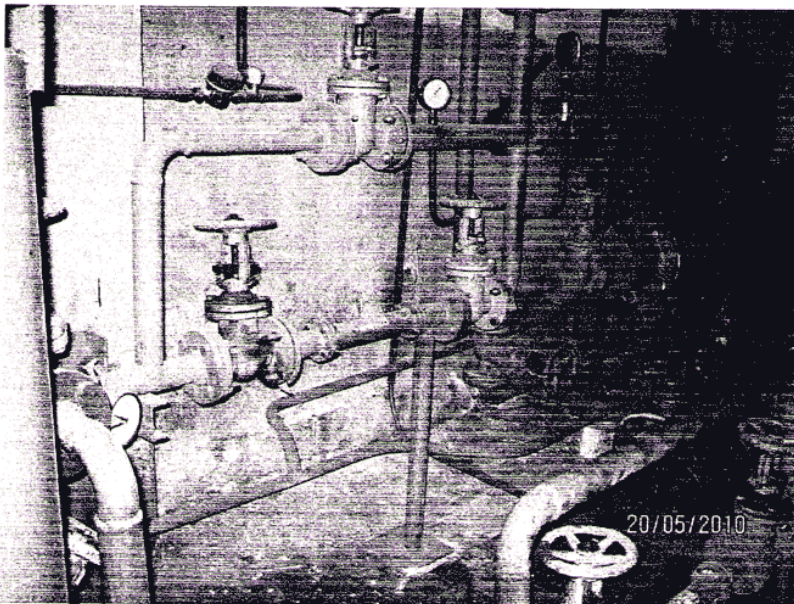

Technical results

Install in boiler fuel feed with work from regular force pumps and for fuel processing in fuel reservoir

Trading port Mariupol, Ukraine.

Recycling of water which is polluted by waste of fuel, oil, black oil...

It is installed on a special boiler-house of trading port Mariupol.

Work from May 2010

Technical results



Install in boiler fuel feed for recycling the mix of water (53%) and black oil (47%) as a fuel.

Boiler-house, Brest Belarus.

Work from Jan. 2009



А Л Ь Я Н С
НОВА ЕНЕРГІЯ УКРАЇНИ

Громадська Організація Альянс «Нова Енергія України»

ДИПЛОМ

Нагороджується переможець
IV Всеукраїнського конкурсу
проектів з енергозбереження та енергоефективності
"Ярмарок ідей-2009"

П.П. Рубан А.В.

в номінації «Кращий реалізований проект»

Голова Правління
Альянсу «Нова Енергія України»

Боровик В. А.



11.09.2009 fourth Ukrainian exhibition energy-saving technologies. Kiev Ukraine.

Devices for boiler fuel economy TRGA have won first place in a nomination " The best realized project on energy conservation in Ukraine "

Example of installation – RUSAL, FRIGUIA ALUMINA REFINERY (GUINEA)

Technology

Friguia uses the Bayer process to produce alumina from bauxite

Development

The company has developed a feasibility study for the Friguia Refinery modernization and expansion project. Hatch, the Canadian Engineering Company, and VAMI, the All Russian Aluminum-Magnesium Institute took part in the development of the feasibility study. The 3-year project is directed to increase the plant's capacity from 640,000 tones to 1 mln tones per annum. Modernization of the plant's facilities will also raise the refinery's production performance and reduce operating costs. Currently the feasibility study is a subject to approval by the independent experts.

www.rusal.ru/en/fria_factory.aspx



10 years RUSAL

More than 40 assets
in 19 countries
on the 5 continents

The image features a worker in a blue uniform and yellow hard hat on the right, looking towards the left. The background is a blue sky. On the left, there is a close-up of industrial machinery with a large yellow spiral component. The RUSAL 10 years logo is in the top left corner, and the text 'More than 40 assets in 19 countries on the 5 continents' is overlaid in the center.

FRIGUIA ALUMINA REFINERY (GUINEA)

Environment

The refinery's modernization program will significantly reduce the environmental impact: a commitment to use ecologically friendly materials by replacing old equipment with environmentally friendly plant will reduce emissions.

www.rusal.ru/en/fria_factory.aspx



FRIGUIA ALUMINA REFINERY (GUINEA)

During May - July 2010 we have analysed full scheme of a fuel feed and have coordinated - type (model) TRGA, an installation site and the plan of carrying out of industrial tests.

All work under the joint analysis, preparation, carrying out of tests, and control and systematization all received results has executed by Mr. Shljaga S.A. – managing director on power supply FRIGUIA SA.

Mr. Shljaga S.A - personally supervised all stages of installation, start, tests and documented results with computer tables and photographed each step of tests. We thank him for high engineering professionalism, honesty and adherence to principles as the official who protects his enterprise interests.

FRIGUIA ALUMINA REFINERY (GUINEA)



FRIGUIA ALUMINA REFINERY (GUINEA)

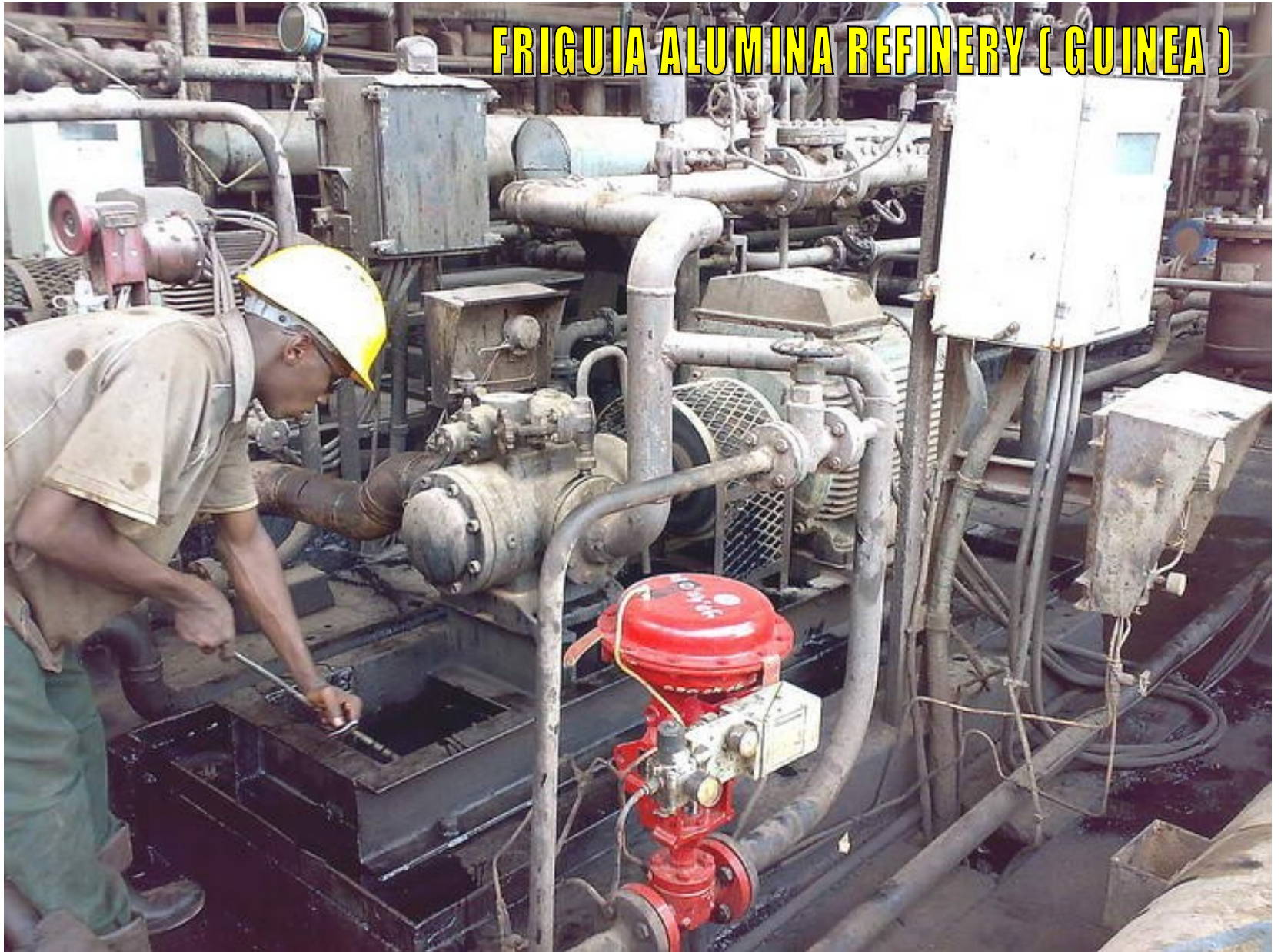

FRIGUIA ALUMINA REFINERY (GUINEA)

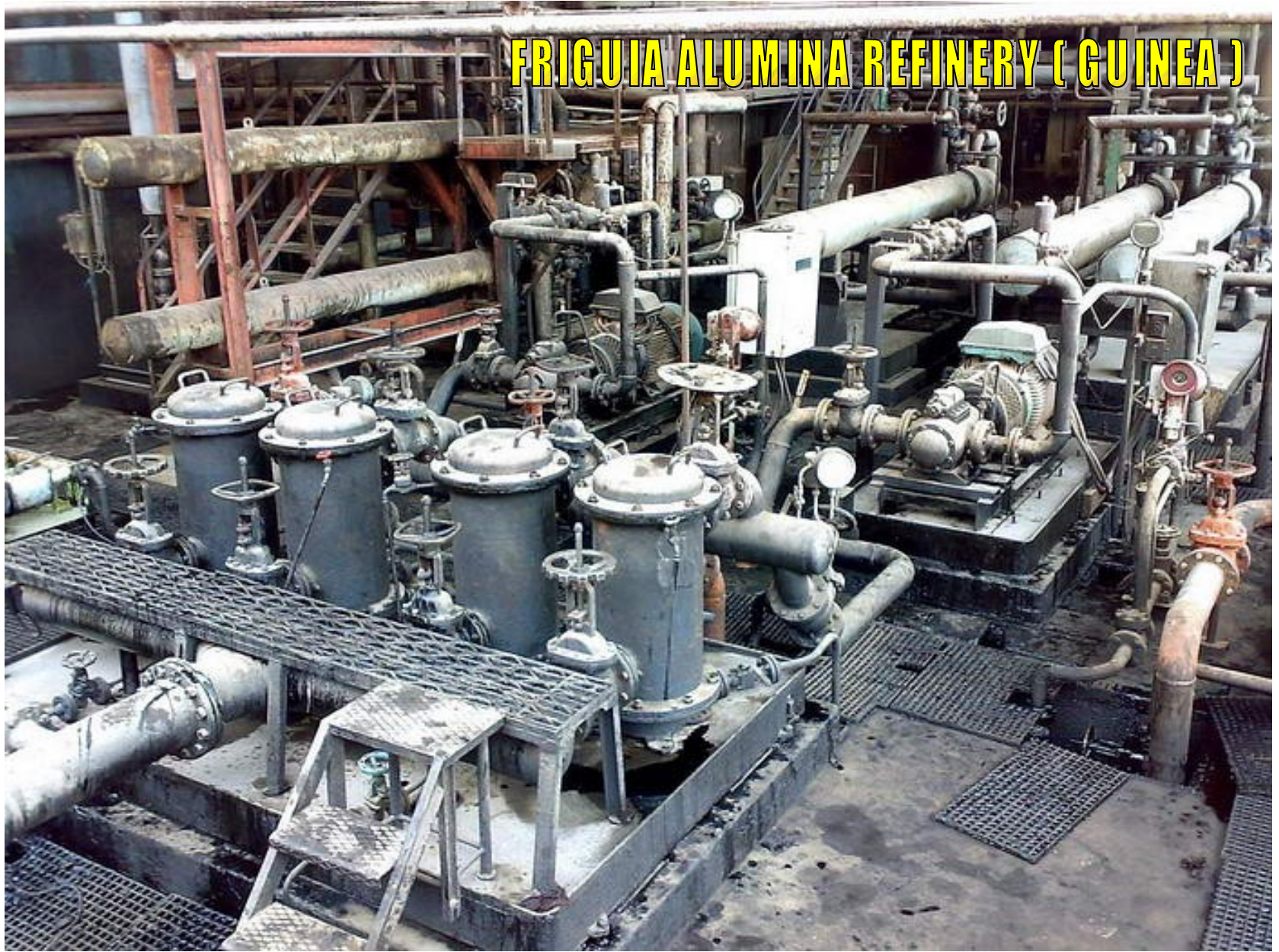

Trafigura Limited

Att. Mrs. Selma Bodvards

Nr. : 10404/00013366/10 – Page 1/1

Date : July 21, 2010



Saybolt

A CORE LABORATORIES COMPANY

**FAST TO THE POINT.
CERTIFICATE**

Product : Fueloil
Vessel : mv."Torm Fox"
Location: : Petronor Bilbao

Test	Unit	Method	Results
Density at 15°C	g/ml	ASTM D-4052	0.9893
Sulphur	%m/m	ASTM D-4294	2.55
Viscosity at 50°C	cSt	ASTM D-445	357
Flash Point PM	°C	ASTM D-93	78
Pour Point	°C	ASTM D-97	-12
Vanadium	Mg/kg	ASTM D-5863	201
Vanadium + Sodium	Mg/kg	ASTM D-5863	234
Sodium	Mg/kg	ASTM D-5863	33
Water by Destillation	% v/v	ASTM D-95	0.10
BSW	% v/v	ASTM D-1796	<0.05
Aluminium + Silicon,	Mg/kg	IP 377	16
Hydrogen Sulphide	mg/kg	IP 399	<2
Asphaltenes,	%P	IP 143	9.3
Gross Specific Value (Calculated)	Btu/US gal	ISO 8217+calc	151225
Shell Hot Filtration Test	%m/m	SMS 2696	
Existent Dry Sludge			0.05
Accelerated Dry Sludge			0.04

Analysis run in external lab.



Quality of black oil - a photo of the black oil reheater

III. Схема установки гомогенизатора TRGA-2-15G на котле №5

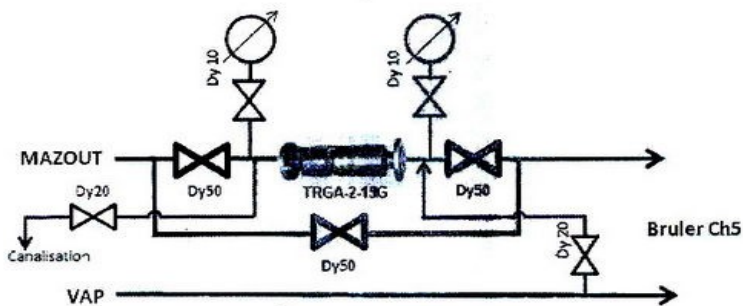
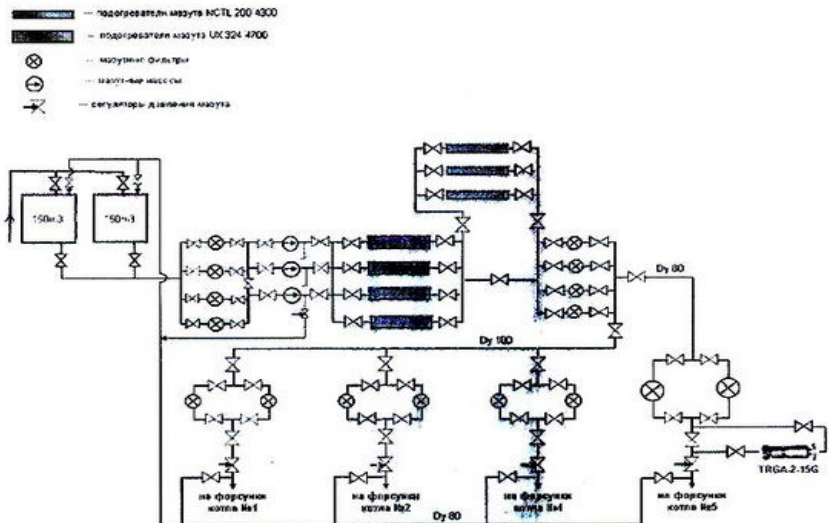

The coordinated place and the scheme of installation of the activator of black oil TRGA

Copy from the official plan of test.

Директор по Энергообеспечению

Согласовано:

Разработчик
гомогенизатора TRGA-2-15G



С.А. Шляга

А.В. Рубан

VUE D'ENSEMBLE CHAUDIERE

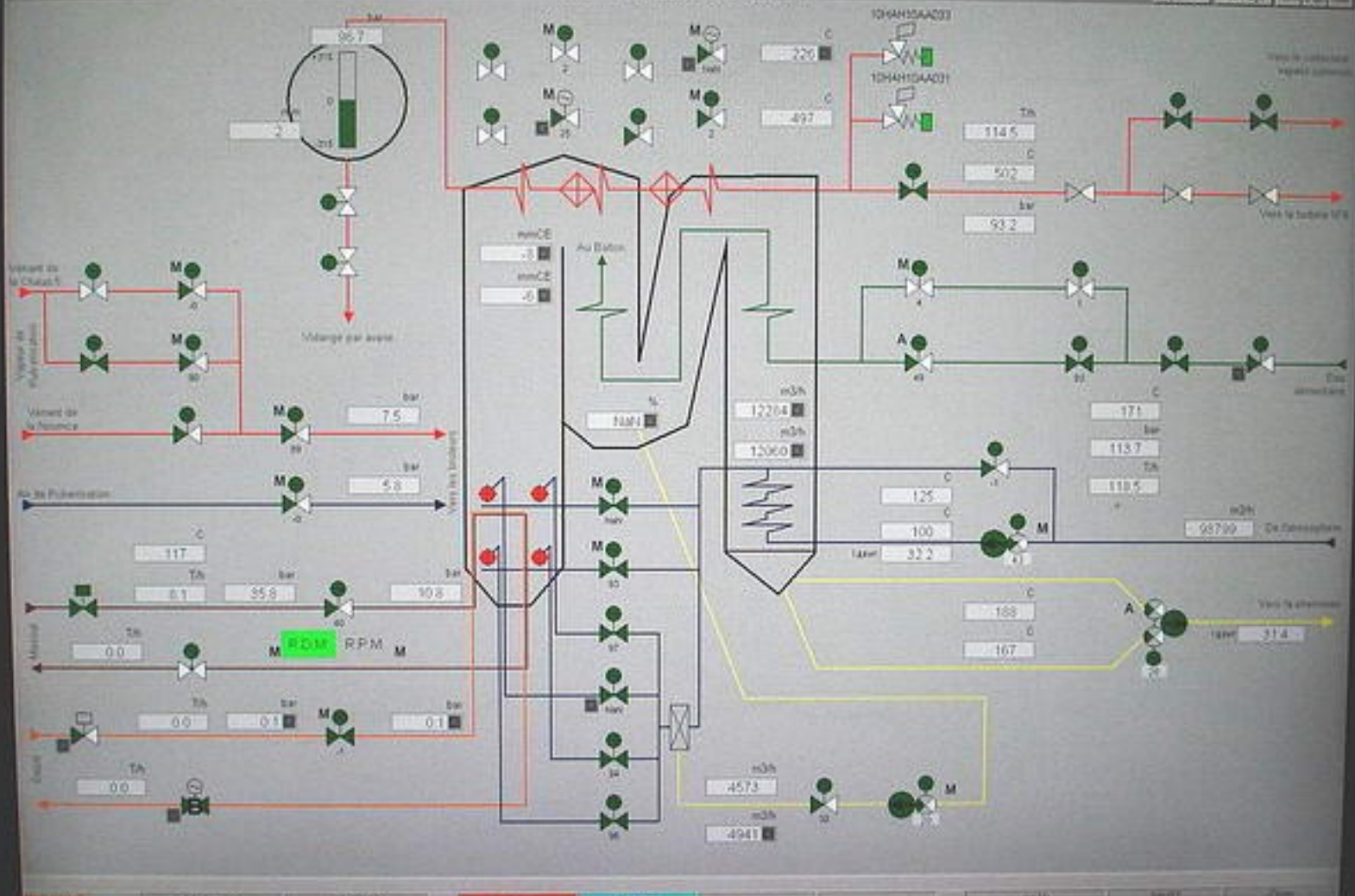



TRGA - start of installation



TRGA - in working



**Color of a torch
(transparency
of the flame)
black oil in that
boiler, after
installation
TRGA, comes
nearer to a
transparency of
diesel fuel
burning**

**Transparent
flame in all
volume of
boiler
furnace**

www.afuelsystems.com/ru/trga/s46.html

part from the first report - (4 sept 2010)

“ 3. Plasma of the general torch in boiler furnace are "soft" very and uniform. The torch almost does not lick front and back screens of boiler furnace.

The boiler furnace it is completely looked through. Very well looked through in boiler furnace a top hamper of screens and screen of super heater. Separation of a flame (presence of flying "front sights") completely is absent.

Separation of a flame (flying " fiery flies ") completely are absent.

4. The smoke from a chimney has an easy bluish shade it similar as solar oil but not black oil burns “

**Transparent
flame in all
volume of
boiler
furnace**



УДМОРАН ТҮҮГА №1
НА ХӨӨ РАБОТАТ КӨЛӨМ №1 И №2
БЕЗ АКТИВАТОРЫ

УДМОРАН ТҮҮГА №2
НА ХӨӨ РАБОТАТ КӨЛӨМ №1
С АКТИВАТОРОМ МАЭГТЭ

труба котла без активатора

труба котла с активатором

Q38

0,0707

Ответить с изменениями... Закончить проверку...

----- Burning of black oil without TRGA ----- burning of black with TRGA

Suiwi rendement activateur de mazout														
Date	CHAUD-5/KOTЕЛ №5				Date	CHAUD-5/KOTЕЛ №5				Date	CHAUD-5/KOTЕЛ №5			
	mazout		vapeur,t	cons.sp écifique		mazout		vapeur,t	cons.sp écifique		mazout/мазут		vapeur/ пар,t	cons.spé cifique/
	m3	t				m3	t				m3	t		
1.7.10	205	197,8	2746	0,072	1.8.10	206	198,8	2739	0,07258	1.9.10		0,0	0	
2.7.10	208	200,7	2786	0,072	2.8.10	205	197,8	2733	0,07238	2.9.10	84	81,1	1006	0,08058
3.7.10	218	210,4	2912	0,0722	3.8.10	206	198,8	2743	0,07247	3.9.10	207	199,8	2866	0,0697
4.7.10	222	214,2	2973	0,0721	4.8.10	206	198,8	2748	0,07234	4.9.10	211	203,6	2904	0,07012
5.7.10	215	207,5	2884	0,0719	5.8.10	205	197,8	2708	0,07305	5.9.10	214	206,5	2939	0,07027
6.7.10	214	206,5	2876	0,0718	6.8.10	205	197,8	2711	0,07297	6.9.10	221	213,3	2954	0,0722
7.7.10	192	185,3	2552	0,0726	7.8.10	208	200,7	2752	0,07294	7.9.10	221	213,3	3025	0,0705
8.7.10	201	194,0	2699	0,0719	8.8.10	212	204,6	2734	0,07483	8.9.10	220	212,3	3016	0,07039
9.7.10	207	199,8	2775	0,072	9.8.10	228	220,0	2848	0,07725	9.9.10	219	211,3	3003	0,07037
10.7.10	204	196,9	2747	0,0717	10.8.10	214	206,5	2780	0,07428	10.9.10	219	211,3	3017	0,07005
11.7.10	206	198,8	2760	0,072	11.8.10	212	204,6	2730	0,07494	11.9.10	217	209,4	2997	0,06987
12.7.10	204	196,9	2725	0,0722	12.8.10	203	195,9	2623	0,07468	12.9.10	220	212,3	3014	0,07044
13.7.10	207	199,8	2777	0,0719	13.8.10	205	197,8	2692	0,07349	13.9.10	221	213,3	3030	0,07038
14.7.10	208	200,7	2794	0,0718	14.8.10	211	203,6	2780	0,07324	14.9.10	221	213,3	3026	0,07048
15.7.10	216	208,4	2874	0,0725	15.8.10	208	200,7	2742	0,0732	15.9.10	219	211,3	2998	0,07049
16.7.10	219	211,3	2918	0,0724	16.8.10	197	190,1	2480	0,07666	16.9.10	209	201,7	2784	0,07244
17.7.10	218	210,4	2888	0,0728	17.8.10	205	197,8	2675	0,07395	17.9.10	145	139,9	1957	0,0715
18.7.10	218	210,4	2900	0,0725	18.8.10	214	206,5	2782	0,07423	18.9.10	0	0,0	0	0
19.7.10	217	209,4	2902	0,0722	19.8.10	216	208,4	2824	0,07381	19.9.10	0	0,0	0	0
20.7.10	213	205,5	2842	0,0723	20.8.10	198	191,1	2594	0,07366	20.9.10	0	0,0	0	0
21.7.10	216	208,4	2889	0,0721	21.8.10	216	208,4	2868	0,07268	21.9.10	0	0,0	0	0
22.7.10	216	208,4	2899	0,0719	22.8.10	215	207,5	2834	0,07321	22.9.10	172	166,0	2270	0,07312
23.7.10	215	207,5	2881	0,072	23.8.10	214	206,5	2821	0,0732	23.9.10	201	194,0	2778	0,06982
24.7.10	215	207,5	2867	0,0724	24.8.10	148	142,8	1947	0,07335	24.9.10	202	194,9	2798	0,06967
25.7.10	214	206,5	2860	0,0722	25.8.10					25.9.10	200	193,0	2764	0,06983
26.7.10	214	206,5	2870	0,072	26.8.10					26.9.10	199	192,0	2733	0,07027
27.7.10	215	207,5	2884	0,0719	27.8.10					27.9.10				
28.7.10	206	198,8	2753	0,0722	28.8.10					28.9.10				
29.7.10	215	207,5	2864	0,0724	29.8.10					29.9.10				
30.7.10	211	203,6	2813	0,0724	30.8.10					30.9.10				
31.7.10	206	198,8	2764	0,0719	31.8.10									
Mois	6555,0	6325,6	87674,0	0,0747	Mois	4957,0	4783,5	64888,0	0,0737	Mois	4242,0	4093,5	57879,0	0,0707

Consommation spécifique mazout de la chaudière n°5 (Mazout,t/Vapeur,t)

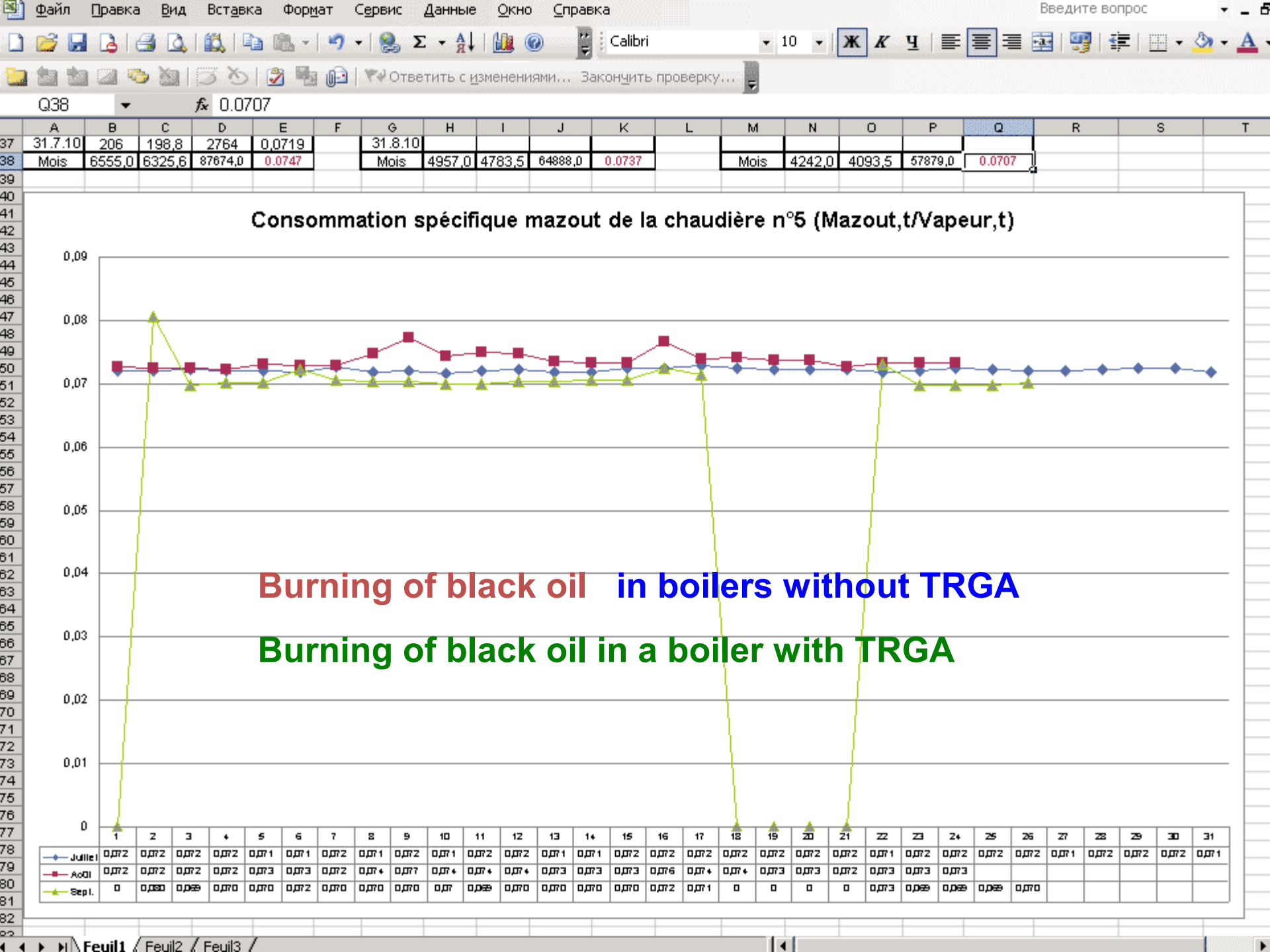

part from the first report - (4 okt 2010)

“After the test of Your homogenizers I do now understand that all statements in the internet about 10% fuel savings is a fairy tale for fools 10% is such a big quantity to save that can be either a miracle or a change calorific value of fuel (a major component fuel which affects its flow)

Today, I examined the boiler and inspected heating surface and I must tell you that TRGA works very well. All that we planned get from this unit we got. It allowed us to achieve fuel savings within 3% and this is firstly a fairly large value economy, and it actually achieved.

Really we get reduced contamination of heating surfaces boiler:

- the screens of firing almost completely clean;**
- no deposits of soot in the convective mine are no deposits of soot, and in**

a tubular evaporator preheater.

There is the deposits soot in air heater, but in 10 times smaller and it is only in stagnant zones. And the tubes for flue gas are absolutely clean”



The surface of heat exchanger (inside the boiler) after 30 days work with the fuel homogenizer TRGA



The surface
of heat
exchanger
(inside the
boiler) after
30 days
work with the
fuel
homogenizer
TRGA



The surface of heat exchanger (inside the boiler) after 30 days work with the fuel homogenizer TRGA



it seems that on the heat exchanger surface was burn all the sulfur.

Since there are no traces of sulfur compounds in the boiler

Previously, all surfaces were covered with yellow-green patina.

The resume

Total difference of two last tables $0.0737 - 0.0707 = 3 \text{ kg} = 4.07 \%$.

This figure above a possible mistake of measurements that is illustrated by schedules of measurements.

(The specific charge of black oil (kg) on 1 ton of steam)

For commercial accounts - madness of this figure is necessary to reducing :
on 1 %, on mistakes, discrepancies and not linearity of work of system

We accept confidently economy of fuel at a level of 3 %,

Every day on this boiler burn about 200 tons of black oil

So the minimal economy of fuel :

= In day = 6 tons of black oil

= In a month = 180 tons of black oil

= For 10 months (the minimal term of work of a boiler in a year) = 1 800 tons.

If the price of black oil is 400 dollars / ton – the economic effect, for one year of operation is 720 000 dollars.

If to use more viscous black oil the economy will tend to increase.

more info ? please ask

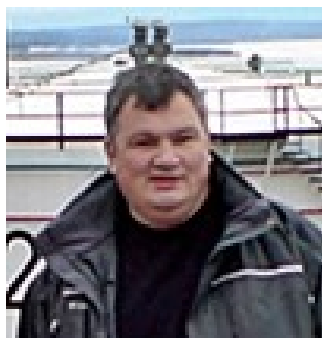

Cherkassy, Ukraine

Andrii V. Ruban

+380 50 5183898

nts01@list.ru



**Ultra-Eko d.o.o.
Republic Slovenia**

Igor Trost

+386 405 80432

trostt53@gmail.com

other info on **www.afuelsystems.com/ru/trga/trga-mz.html**